

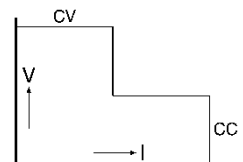

## SM1500 - Series 1500W DC POWER SUPPLIES

Models	Voltage range	Current range
SM 15-100	0 - 15 V	0 - 100 A
SM 35-45	0 - 35 V	0 - 45 A
SM 52-30	0 - 52 V	0 - 30 A
SM 52-AR-60 Autoranging output	0 - 26 V 0 - 52 V	0 - 60 A 0 - 30 A
SM 70-22	0 - 70 V	0 - 22 A
SM 120-13	0 - 120 V	0 - 13 A
SM 300-5	0 - 300 V	0 - 5 A
SM 400-AR-8 Autoranging output	0 - 200 V 0 - 400 V	0 - 8 A 0 - 4 A

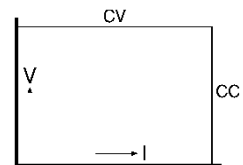

### Features

- cTUVus safety approval
- Designed for long life at full power
- Excellent dynamic response to load changes
- Protected against all overload and short circuit conditions
- EMC surpasses CE requirements: low emission & high immunity
- Low audible noise: temperature controlled fans
- Available options: analog & digital Interfaces, High Speed Programming, Digital Encoders, Sequencer, Power Sink etc.

### Functionalities

- Master/Slave parallel and series operation with voltage and current sharing
- Stacking is allowed, space between units is not required
- High power system configuration from multiple units
- 19" rack mounting or laboratory use (feet included)
- Remote sensing
- Interlock

	SM 15-100	SM 35-45	SM 52-30	SM 52-AR-60	SM 70-22	SM 120-13	SM 300-5	SM 400-AR-8
<b>DC Power terminals</b>								
voltage	0 - 15 V	0 - 35 V	0 - 52 V	0 - 52 V	0 - 70 V	0 - 120 V	0 - 300 V	0 - 400 V
current	0 - 100 A	0 - 45 A	0 - 30 A	0 - 60 A	0 - 22 A	0 - 13 A	0 - 5 A	0 - 8 A
AUTORANGING (2 ranges)	no	no	no	yes	no	no	no	yes
Max. output current / voltages	/	/	/	60 A / 0-26 V 30 A / 26-52 V	/	/	/	8 A / 0-200 V 4 A / 200-400 V
<b>AC Input</b>								
single phase, 48 - 62 Hz	90-265 V	90-265 V	90-265 V	90-265 V	90-265 V	90-265 V	90-265 V	90-265 V
rated voltage range	100-240 V	100-240 V	100-240 V	100-240 V	100-240 V	100-240 V	100-240 V	100-240 V
rated frequency	50 / 60 Hz	50 / 60 Hz	50 / 60 Hz	50 / 60 Hz	50 / 60 Hz	50 / 60 Hz	50 / 60 Hz	50 / 60 Hz
rated current	max 16A	max 16A	max 16A	max 16A	max 16A	max 16A	max 16A	max 16A
Power Derating vs input:								
90 V : P <sub>out max</sub> (W), I <sub>in</sub> (A)	1170, 16	1185, 16	1200, 16	1200, 16	1200, 16	1200, 16	1200, 16	1200, 16
100 V : P <sub>out max</sub> (W), I <sub>in</sub> (A)	1317, 16	1334, 16	1350, 16	1350, 16	1350, 16	1350, 16	1350, 16	1350, 16
110 V : P <sub>out max</sub> (W), I <sub>in</sub> (A)	1492, 16	1498, 16	1505, 16	1505, 16	1505, 16	1505, 16	1505, 16	1505, 16
<b>230 V : P<sub>out max</sub> (W), I<sub>in</sub> (A)</b>	1500, 7.5	1575, 7.7	1560, 7.7	1560, 7.7	1540, 7.6	1560, 7.7	1500, 7.4	1600, 7.8
power factor, 100%, 50% load	0.99, 0.98	0.99, 0.98	0.99, 0.98	0.99, 0.98	0.99, 0.98	0.99, 0.98	0.99, 0.98	0.99, 0.98
internal fuses	25 AT	25 AT	25 AT	25 AT	25 AT	25 AT	25 AT	25 AT
standby input power (V <sub>o</sub> =I <sub>o</sub> =0)	12 W	12 W	12 W	12 W	12 W	12 W	12 W	12 W
standby input power (V <sub>o</sub> =V <sub>max</sub> )	22 W	22 W	22 W	22 W	22 W	22 W	22 W	25 W
				26 V / 52 V				200 V / 400 V
<b>Efficiency</b>								
230 V AC, 1 ph input, full load	87 %	90 %	90 %	89 / 90 %	90 %	90 %	91 %	90 / 91 %
115 V AC, 1 ph input, full load	83 %	86 %	86 %	84 %	86 %	86 %	86 %	86 %
<b>Regulation</b>								
Load 0 - 100% <b>CV</b>	0.5 mV	1 mV	2 mV	2 mV	2.5 mV	4 mV	10 mV	12 mV
Line 120 - 265 V AC <b>CV</b> (measured on sense block)	0.2 mV	0.5 mV	0.7 mV	0.7 mV	1 mV	2 mV	3 mV	4 mV
Load 0 - 100% <b>CC</b>	5 mA	3 mA	1.5 mA	2 mA	1 mA	0.6 mA	0.5 mA	0.5 mA
Line 120 - 265 V AC <b>CC</b> (internal voltage sense)	1 mA	0.5 mA	0.5 mA	1 mA	0.25 mA	0.2 mA	0.1 mA	0.2 mA
<b>Ripple + noise</b>								
rms (BW=300 kHz) <b>CV</b>	2 mV	1.8 mV	2 mV	2 mV	3 mV	7 mV	7 mV	15 mV
p-p (BW=20 MHz) <b>CV</b>	8 mV	8 mV	15 mV	15 mV	15 mV	30 mV	50 mV	80 mV
rms (BW=300 kHz) <b>CC</b>	15 mA	5 mA	3 mA	10 / 3 mA	3 mA	2 mA	0.5 mA	1.2 / 0.6 mA
p-p (BW=20 MHz) <b>CC</b> CC-ripple at full load	80 mA	15 mA	10 mA	30 / 10 mA	10 mA	6 mA	4 mA	6 / 3 mA
<b>Temp. coeff., per °C<sup>-1</sup></b> <b>CV</b>					35.10 <sup>-6</sup>			
<b>CC</b>					60.10 <sup>-6</sup>			
<b>Stability</b> <sup>1</sup> after 1 hr warm-up during 8 hrs <b>CV</b>					6.10 <sup>-5</sup>			
<b>CC</b>					9.10 <sup>-5</sup>			
t <sub>amb</sub> = 25 ± 1 °C, V <sub>in</sub> = 230 VAC					(internal voltage sensing for CC-stab.)			

<b>Analog Programming</b>	<b>CV</b>	<b>CC</b>
<b>Programming inputs</b>		
input range	0 - 5 V	0 - 5 V
accuracy	± 0.2%	± 0.5%
offset	- 0.1 ... +1.3 mV (on 5V)	0 ... +2.2 mV (on 5V)
temp. coeff. offset	10 µV / °C	50 µV / °C
input impedance	> 1 MOhm	> 1 MOhm
<b>Monitoring outputs</b>		
input range	0 - 5 V	0 - 5 V
accuracy	± 0.2%	± 0.2%
offset	- 1 ... 0 mV (on 5V)	- 1.1 ... 0 mV (on 5V)
temp. coeff. offset	3 µV / °C	60 µV / °C
input impedance	2 Ohm / max. 4mA	2 Ohm / max. 4mA
<b>ISO AMP Programming (optional)</b>	Isolated analog programming, range 0 - 5 V / 200 kOhm or 0 - 10 V / 400 kOhm. See datasheet ISO AMP on <a href="http://www.DeltaPowerSupplies.com">www.DeltaPowerSupplies.com</a> for accuracy, offset etc.	
<b>Reference voltage</b>		
on prog. connector	5.114 ±15 mV (R <sub>o</sub> = 2 Ohm, max. 4 mA)	
V <sub>ref</sub>	20 ppm	
TC		
<b>+12 V output</b>		
on prog. Connector	12 V ± 0.2 V	
V <sub>o</sub>	0.2 A	
I <sub>max</sub>	3 Ohm	
R <sub>o</sub>		

Notes: 1. Measured at full load. 2. See "Safety instructions".

<b>Status Outputs</b>	CC - status LIM - status OT - status PSOL - status ACF - status DCF - status	CC - operation CV or CC limit Over Temperature Power Sink Overload AC - Fail DC - Fail <sup>1)</sup>	5 V = logic 1 (Ro = 500 Ohm) 5 V = logic 1 (Ro = 500 Ohm) 5 V = logic 1 (Ro = 500 Ohm) 5 V = logic 1 (Ro = 500 Ohm) 5 V = logic 1 (Ro = 500 Ohm) 5 V = logic 1 (Ro = 500 Ohm)
<b>Relay Outputs</b>	ACF DCF	AC - Fail DC - Fail <sup>1)</sup>	both NO and NC contact both NO and NC contact <sup>1)</sup> output ± 5% beyond set point
<b>Remote shutdown</b>	with + 5 V, 1 mA or relay contact		
<b>Interlock</b>	contact at rear panel, see photo of rear panel on page 1-6		
<b>Indicators</b> (front panel)	AC-Fail, DC-Fail, Over Temperature, Power Sink Overload, Remote-ShutDown, Remote-CV, Remote-CC, Output On, CV-limit, CC-limit, CV- and CC- mode		
<b>Controls</b> (front panel)	Mains on/off, CV-and CC-potmeter, CV- and CC-limit-potmeter, Display-Settings button, Display-Limits button, Remote/Local, Output On/Off, Front panel Lock		

<b>Programming speed</b> <i>Standard Version</i> (resistive load)	SM 15-100	SM 35-45	SM 52-30	SM 52-AR-60	SM 70-22	SM 120-13	SM 300-5	SM 400-AR-8
<b>Rise time (10 - 90%)</b>								
output voltage step	0 → 15 V	0 → 35 V	0 → 52V	0 → 26 V	0 → 70 V	0 → 120 V	0 → 300 V	0 → 200 V
time, (100 % load)	6.1 ms	15.4 ms	7.3 ms	8.5 ms	13.2 ms	3.4 ms	9 ms	3.7 ms
time, (10 % load)	2.1 ms	5.1 ms	2.4 ms	2.8 ms	4.4 ms	2 ms	3.9 ms	2.6 ms
output voltage step	-	-	-	0 → 52 V	-	-	-	0 → 400 V
time, (100 % load)	-	-	-	34.2 ms	-	-	-	15 ms
time, (10 % load)	-	-	-	11 ms	-	-	-	5 ms
<b>Fall time (90 - 10%)</b>								
output voltage step	15 → 0 V	35 → 0 V	52 → 0 V	26 → 0 V	70 → 0 V	120 → 0 V	300 → 0 V	200 → 0 V
time, (100 % load)	6.1 ms	14.7 ms	7 ms	8.2 ms	12.9 ms	3.3 ms	9 ms	3.5 ms
time, (10 % load)	61 ms	147 ms	70 ms	82 ms	129 ms	33 ms	90 ms	35 ms
output voltage step	-	-	-	52 → 0 V	-	-	-	400 → 0 V
time, (100 % load)	-	-	-	33 ms	-	-	-	14.2 ms
time, (10 % load)	-	-	-	330 ms	-	-	-	142 ms
<b>Programming speed</b> <i>Optional High Speed</i> (resist. load)	SM 15-100 <i>Option P210</i>	SM 35-45 <i>Option P211</i>	SM 52-30 <i>Option P212</i>	SM 52-AR-60 <i>Option P213</i>	SM 70-22 <i>Option P214</i>	SM 120-30 <i>Option P215</i>	SM 300-5 <i>Option P216</i>	SM 400-AR-8 <i>Option P217</i>
<b>Rise time (10 - 90%)</b>								
output voltage step	0 → 15 V	0 → 35 V	0 → 52V	0 → 26 V	0 → 70 V	0 → 120 V	0 → 300 V	0 → 200 V
time, (100 % load)	0.20 ms	0.27 ms	0.32 ms	0.44 ms	0.47 ms	0.46 ms	1.0 ms	0.35 ms
time, (10 % load)	0.11 ms	0.14 ms	0.22 ms	0.45 ms	0.27 ms	0.27 ms	0.51 ms	0.33 ms
output voltage step	-	-	-	0 → 52 V	-	-	-	0 → 400 V
time, (100 % load)	-	-	-	0.42 ms	-	-	-	0.98 ms
time, (10 % load)	-	-	-	0.34 ms	-	-	-	0.59 ms
<b>Fall time (90 - 10%)</b>								
output voltage step	15 → 0 V	35 → 0 V	52 → 0 V	26 → 0 V	70 → 0 V	120 → 0 V	300 → 0 V	200 → 0 V
time, (100 % load)	0.21 ms	0.33 ms	0.39 ms	0.48 ms	0.67 ms	0.51 ms	1.4 ms	0.35 ms
time, (10 % load)	1.6 ms	3.5 ms	3.6 ms	1.9 ms	6.4 ms	4.5 ms	13 ms	3.8 ms
output voltage step	-	-	-	52 → 0 V	-	-	-	400 → 0 V
time, (100 % load)	-	-	-	0.7 ms	-	-	-	1.7 ms
time, (10 % load)	-	-	-	6.5 ms	-	-	-	18 ms
<b>Ripple</b> @ full load				26 V / 60 A				200V
typical (rms/pp)	20 / 80 mV	50 / 150 mV	50 / 185 mV	20 / 90 mV	30 / 125 mV	20 / 80 mV	25 / 115 mV	85 / 355 mV
typical (rms/pp)				52 V / 30A				400 V
				20 / 90mV				60 / 245 mV
<b>Output Capacitance</b> (typical)	390 µF	190 µF	135 µF	228 µF	135 µF	21 µF	10 µF	7 µF

	SM 15-100	SM 35-45	SM 52-30	SM 52-AR-60	SM 70-22	SM 120-13	SM 300-5	SM 400-AR-8
<b>Recovery time</b>				26 / 52 V				200 / 400 V
recovery within	50 mV	50 mV	100 mV	60 mV	100 mV	0.7 V	1.0 V	1.0 / 0.5 V
di/dt of load step	1.5 A/µs	0.8 A/µs	0.5 A/µs	1.0/0.5 A/µs	0.4 A/µs	0.2 A/µs	0.1 A/µs	0.2/0.1 A/µs
output voltage	14 V	30 V	48 V	24 / 48 V	65 V	110 V	280 V	185 / 370 V
time, @ 50 - 100% load step	100 µs	100 µs	100 µs	100 / 100 µs	100 µs	100 µs	100 µs	100 / 100 µs
max. deviation	200 mV	150 mV	250 mV	200/100 mV	200 mV	2.2 V	1.5 V	2.5 / 1.5 V
<b>Output impedance</b>								
CV, 0-1 kHz	< 1.3 mΩ	< 1.7 mΩ	< 3.5 mΩ	< 3.3 mΩ	< 7.5 mΩ	< 63 mΩ	< 125 mΩ	< 83 mΩ
CV, 1-100 kHz	< 25 mΩ	< 30 mΩ	< 30 mΩ	< 40 mΩ	< 30 mΩ	< 600 mΩ	< 1 Ω	< 1.3 Ω
<b>Pulsating load</b> max. tolerable AC component of load current								
f > 1 kHz	15 A <sub>rms</sub>	15 A <sub>rms</sub>	13 A <sub>rms</sub>	20 A <sub>rms</sub>	13 A <sub>rms</sub>	2.5 A <sub>rms</sub>	1.2 A <sub>rms</sub>	0.8 A <sub>rms</sub>
f < 1 kHz	100 A <sub>peak</sub>	45 A <sub>peak</sub>	30 A <sub>peak</sub>	60 / 30 A <sub>peak</sub>	22 A <sub>peak</sub>	13 A <sub>peak</sub>	5 A <sub>peak</sub>	8 / 4 A <sub>peak</sub>

<b>Insulation</b> AC mains / DC power terminals creepage / clearance AC mains / case DC power terminals / case	3750 V <sub>rms</sub> (1min.) 8 mm 2500 V <sub>rms</sub> 600 V DC <sup>2</sup>
<b>Safety</b>	cTUVus / EN 60950 / EN 61010
<b>EMC</b> <b>Generic Emission</b> <b>Generic Immunity</b>	<b>EN 61326-1</b> , class B equipment (for use in domestic establishments) <b>EN 61326-1</b> , equipment for use in industrial and domestic establishments

<b>Operating Temperature</b>	- 20 to + 50 °C @ full load, derate output to 75% at 60 °C
<b>Humidity</b>	maximum 95% RH, non condensing, up to 40 °C maximum 75% RH, non condensing, up to 50 °C
<b>Storage temperature</b>	- 40 to + 85 °C
<b>Thermal protection</b>	output shuts down in case of insufficient cooling
<b>MTBF</b>	500 000 hrs

<b>Hold-Up time</b> (@ 230 VAC input) V <sub>out</sub> = 100%, I <sub>out</sub> = 100% V <sub>out</sub> = 85%, I <sub>out</sub> = 100% V <sub>out</sub> = 100%, I <sub>out</sub> = 50%	16 ms 20 ms 36 ms
<b>Turn on delay</b> after mains switch on	480 ms @ 230 VAC, 700 ms @ 115 VAC
<b>Inrush current</b>	22 A @ 230 VAC, 27 A @ 115VAC

	SM 15-100	SM 35-45	SM 52-30	SM 52-AR-60	SM 70-22	SM 120-13	SM 300-5	SM 400-AR-8
<b>Series operation</b> max. total voltage Master / Slave operation	600 V <sup>2</sup> yes							
<b>Parallel operation</b> Normal Master / Slave operation	no limit maximum 4 units							
<b>Remote sensing</b> max. voltage drop per load lead	2 V							
<b>Limits</b> <b>Voltage</b> adjust range <b>Current</b> adjust range	0 - 102 % 0 - 102 %							
<b>Front panel CV/CC-controls</b> resolution knob operation screwdriver adjustment  Lock function for CV/CC-settings Selectable Start-up at 0V / 0A or at last settings	analog potentiometers <sup>3)</sup> 10 turns (0.03%) standard optional (P001)  no <sup>3)</sup> no <sup>3)</sup>  <sup>3) optional with digital encoders (P220).</sup>							
<b>Meters</b> scale voltage scale current accuracy read output read limit setting (d = digit)	3.5 digit 0 - 15.00V 0 - 100.0 A 0.5% + 2d 2% + 2d	3.5 digit 0 - 35.0 V 0 - 45.0 A 0.5% + 2d 2% + 2d	3.5 digit 0 - 52.0 V 0 - 30.0A 0.5% + 2d 2% + 2d	3.5 digit 0 - 52.0 V 0 - 60.0A 0.5% + 2d 2% + 2d	3.5 digit 0 - 70.0V 0 - 22.0 A 0.5% + 2d 2% + 2d	3.5 digit 0 - 120.0V 0 - 13.00 A 0.5% + 2d 2% + 2d	3.5 digit 0 - 300 V 0 - 5.00 A 0.5% + 2d 2% + 2d	3.5 digit 0 - 400 V 0 - 8.00 A 0.5% + 2d 2% + 2d

<b>Mounting</b>	stacking of units allowed, air flow is from left to right
<b>AC Terminals</b>	IEC320/C20, EN60320/C20
<b>DC Terminals</b>	M8 bolts
<b>Programming connector</b>	15 pole D-connector at rear panel (Female)
<b>Interlock</b>	contact at rear panel
<b>Cooling</b> audio noise level  air flow	low noise blower, fan speed adapts to temperature of internal system ca. 45 dBA at full load, 25 °C ambient temperature, 1 m distance ca. 50 dBA at full load, 50 °C ambient temperature, 1 m distance From left to right
<b>Enclosure</b> degree of protection	IP20
<b>Dimensions</b> front panel: h x w behind front panel: h x w x d	89 x 483 mm (19", 2 U) 89 x 443 x 365 mm
<b>Weight</b>	9.9 kg

Notes: 1. Measured at full load. 2. See "Safety instructions".

## Typical Applications

- Solar inverter testing, PV-Simulation
- Hybrid Car testing systems
- ATE in industrial production lines
- Plasma chambers
- Automotive battery simulations
- Controlled battery (dis)charging
- Lasers
- Sustainable energy
- Driving PWM-Controlled DC motors
- Accurate current sources
- Aerospace and military equipment

## Available Options



### Increased Output Power

The conservatively rated unit allows to deliver extra output with the same reliability.

At some derating, either the maximum output voltage or the maximum output current can be increased by about 10%.

Order Code :

- P069



### High Speed Programming

A 10 to 20 times higher programming speed (down to 0.2ms rise time at full load) and lower output capacitance<sup>1)</sup>. Excellent for laser applications, test systems or as current source with low parallel capacitance as used in plasma chambers.

Order Codes :

- SM 15-100 P210 – SM35-45 P211
- SM 52-30 P212 – SM52-AR-60 P213
- SM 70-22 P214 – SM120-13 P215
- SM 300-5 P216 – SM400-AR-8 P217



### Two-Quadrant Output Power Sink

Two quadrant operation maintains the DC output voltage constant regardless the output power is positive or negative<sup>1)</sup>. Ideal for PWM-speed controlled DC-Motors and ATE systems.

Order Codes :

- SM 15-100 P202 – SM35-45 P203
- SM 52-30 P204 – SM52-AR-60 P205
- SM 70-22 P206



### Sequencer

Arbitrary Waveform generator or standalone automation. The sequencer

Is integrated in the Ethernet controller.

Order Code :

- P177



### Digital CV- and CC-Settings

Reliable, long-life digital encoders can be implemented at the front panel. Includes total front panel lock (also for CV- / CC-knobs) and a coarse or fine pitch adjustment depending on the turning speed.

Order Code :

- P220



### Secured Voltage and Current Settings

For maximum security, the CV/CC settings can be adjusted with a screwdriver only and are protected with a plastic cap from accidental adjusting.

Order Code :

- P001



### Software Control and Interfaces

Interfaces to be installed by factory <sup>2)</sup>.

Order Code:

- Ethernet controller (including sequencer) - P177
- ISO AMP Card - isolated analog - P218
- RS232 controller - P183
- IEEE488 controller - P184
- PROFIBUS controller - P273
- CANBUS controller - P274

Notes: 1. Download datasheets about High Speed Programming, Power Sink and Battery Charging from [www.DeltaPowerSupplies.com](http://www.DeltaPowerSupplies.com).  
2. There is only room for one of the interfaces in a unit.

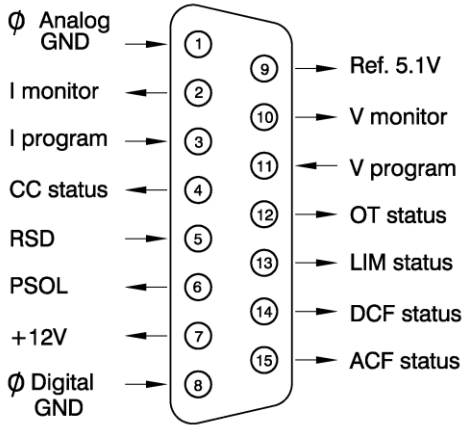

CV = Constant Voltage  
 CC = Constant Current

Specifications measured at  
 $t_{amb} = 25 \pm 5 \text{ }^\circ\text{C}$  and  $V_{in} = 230 \text{ VAC}$ ,  
 50 Hz unless otherwise noted.

The information in this document is  
 subject to change without notice.

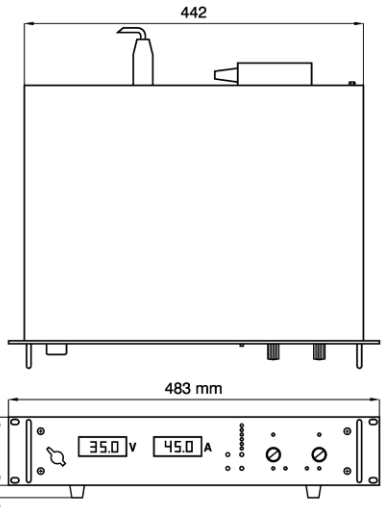

Connections analog programming connector

