

REAL TIME CROSS CORRELATION



RoHS

HA7063A

50GHz DOWNCONVERTER

COMPATIBLE WITH:

- HA7062C PHASE NOISE ANALYZER
- HA7062D PHASE NOISE ANALYZER

Real Time Data Acquisition

DATA SHEET

October 2020

PRODUCT SUMMARY

The **HA7063A 50GHz Downconverter** extends the frequency range of Holzworth's HA7062C and HA7062D Real Time Phase Noise Analyzers to 50GHz. The 2x 1U chassis configuration operates as a single phase noise test system. The HA7063A and HA7062C/D connect via RF cabling on the front panels, along with an RS-232 connection on the rear panel so there is no need for independent control. Users communicate via a single Ethernet, USB, or GPIB connection to the test system.

MEASURED NOISE FLOORS: Holzworth phase noise analysis solutions offer the unique feature to measure the true noise floor of each phase noise analyzer, while alternative options provide a confidence factor calculation that is often misinterpreted as being the actual noise floor. The HA7062C and HA7062D Real Time Phase Noise Analyzer products were designed to provide direct access to the phase detectors (mixers) to enable measurement of the analyzer's true noise floor. The HA7063A also offers this feature as a factory configured option.

UNPARALLELED ANALOG PERFORMANCE: The HA7063A utilizes Holzworth ultra low noise HSX series synthesizers to down-convert incoming signals into an acceptable range for the phase noise analyzer. The phase noise analyzers utilize real time dual FFT engines at its core, but everything begins at the ultra-low noise analog front end. A key component of the analyzer's analog front end is another pair of Holzworth HSX Series RF Synthesizers as the analyzer's internal LO's. These ultra-low noise RF sources (LOs) complement the extremely fast and low noise measurement capability. The test system provides user access to 2x 6GHz synthesizers and 2x 24GHz synthesizers for general purpose use.

REPEATABLE DATA: Holzworth's fully shielded, fan-less 1U chassis eliminates ground loops and troublesome microphonics for uncompromised performance and repeatability. See it for yourself knowing that Holzworth encourages running head-head tests with the competition. Contact Holzworth directly for availability of an evaluation unit in your area.

REAL-TIME FULL BANDWIDTH DATA ACQUISITION**VERSATILE - RECONFIGURABLE FRONT END****MEASURE: PM / AM / BASEBAND / SPURIOUS / JITTER****ISOLATED AM/PM MEASUREMENTS****AUTOMATED RESIDUAL MEASUREMENTS****3 YEAR MANUFACTURER WARRANTY**

PRODUCT SUMMARY - BLOCK DIAGRAM

VERSATILE: The HA7063A is a result of more than a decade of product development that reflects valuable customer feedback and Holzworth's direct experience with measuring phase noise in our own manufacturing environment. The end result goes well beyond accuracy, reliability and speed. The reconfigurable front end allows users to tailor the analyzer for their specific measurement needs.

The HA7063A is designed to seamlessly integrate with either the HA7062C or the HA7062D Real Time Phase Noise Analyzer products. Specific RF jumper cable connections are required at the front panel with an I/O jumper cable connector at the rear panel. With the two units properly connected, they become one unit and operate via a single application GUI.

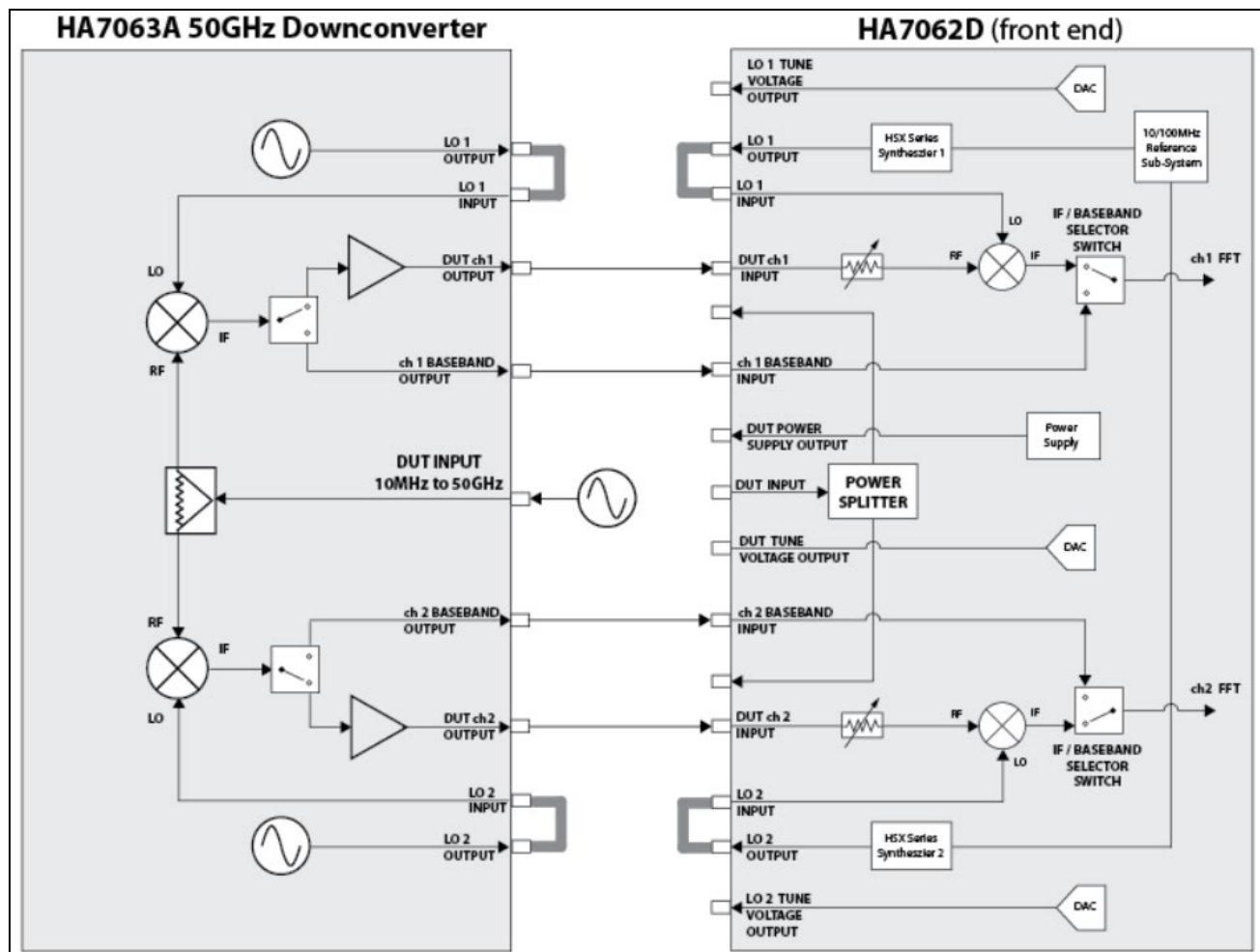

With the HA7063A integration kit, a user will also receive either a benchtop bracket kit or a communications rack installation kit. Both kits are designed to securely house the HA7063A and the HA7062C/D for ease of integration and/or mobility.

HA7063A SPECIFICATIONS

The specifications outlined here capture the baseline performance and features that are currently available from the HA7063A + HA7062D / HA7062C phase noise analysis system.

MEASUREMENT MODES

MODE	DESCRIPTION
Absolute	Internal synthesized LO sources. Auto tune and phase lock. Connect DUT Signal direct to HA7063A.
Absolute with External LOs	External LO Inputs available on HA7063A and HA7062D/HA7062C
Additive/Residual	External Signal Source and phase shifters required.
AM Noise	Characterize AM noise of RF input signal
Baseband	Baseband measurements out to 100MHz offset (with HA7062D)
Spurious Analysis Toolbox	Provides spurious performance data based on a user settable Spur Threshold.

DUT INPUT

DESCRIPTION	SPECIFICATION
DUT Input Connector	2.4mm (female), 50 ohm
DUT Input Frequency Range Absolute Measurements Residual (Additive) Measurements AM Measurements External LO PM Measurements Baseband Measurements	10 MHz to 50 GHz 1 GHz to 50 GHz (can be reconfigured to measure to 10MHz DUT input) ¹ 10 MHz to 50 GHz 1 GHz to 50 GHz 0.1 Hz to 100 MHz
DUT Input Measurement Level 10 MHz to 6 GHz >6 GHz to 18 GHz >18 GHz to 32 GHz >32 GHz to 50 GHz	-20 dBm to +20 dBm (Subtract 10 dBm from lower limit for typical sensitivity) -10 dBm to +20 dBm (Subtract 10 dBm from lower limit for typical sensitivity) - 0 dBm to +20 dBm (Subtract 10 dBm from lower limit for typical sensitivity) +10 dBm to +20 dBm (Subtract 10 dBm from lower limit for typical sensitivity)
DUT Input Damage Level	+22 dBm
RF Tracking Range	±10ppm (typical), ± 5ppm (specified)
Cross-Correlation Noise Floor	Refer to pages 8-9 for measured noise floor data.

¹ Additive/Residual measurements in the frequency range of 10 MHz to 1 GHz can be performed using the DUT input port of the HA7062C/D.

HA7063A SPECIFICATIONS (cont.)
MEASUREMENT BANDWIDTH & UNCERTAINTY

DESCRIPTION	SPECIFICATION
Offset Frequency Range (w/ HA7062D) PM Measurements AM Measurements Baseband Measurements	0.1Hz to 100 MHz 0.1Hz to 1 MHz 0.1Hz to 100 MHz
Offset Frequency Range (w/ HA7062C) PM Measurements AM Measurements Baseband Measurements	0.1Hz to 40 MHz 0.1Hz to 1 MHz 0.1Hz to 40 MHz
Phase Noise Uncertainty (Absolute Measurements) 1 Hz to 10 Hz offset 10 Hz to 1 kHz offset 1 kHz to 100 MHz offset	± 4 dB ± 3 dB ± 2 dB
Phase Noise Uncertainty (Additive Measurements) 1 Hz to 1 kHz offset 1 kHz to 100 MHz offset	± 3 dB ± 2 dB

DUT CH1 / DUT CH2 OUTPUTS (IF FREQUENCY OUTPUTS)

DESCRIPTION	SPECIFICATION
DUT Output Connectors	SMA (female), 50 ohm
DUT Output Frequency (IF Frequency)	DC to 400 MHz
IF Gain Standard User Selectable	Auto Select 6 dB, 12 dB, 24 dB, 36 dB, 48 dB

LO INPUTS

DESCRIPTION	SPECIFICATION
LO Input Connector	2.4mm (female), 50 ohm
LO Input Frequency Range	1 GHz to 50 GHz
LO Input Level	+15 dBm to +19 dBm

HA7063A SPECIFICATIONS (cont.)

LO OUTPUTS

The HA7063A internal LOs are from Holzworth's HSX Series RF Synthesizers and are available to the user as general purpose CW signal sources via the front panel. Removing the LO jumper cables provides direct access to these signal sources.

DESCRIPTION	SPECIFICATION
LO Output Connector	SMA (female), 50 ohm
LO Output Frequency Range	10 MHz to 24 GHz
LO Output Power 10 MHz < f ≤ 16.0 GHz 16.0 GHz < f ≤ 20.0 GHz 20.0 GHz < f ≤ 24.0 GHz	-30 dBm to +18 dBm -30 dBm to +16 dBm -30 dBm to +14 dBm

INTERNAL TIME BASE (10/100MHz Reference Module)

DESCRIPTION	SPECIFICATION
Frequency Uncertainty / Stability	< ± 1Hz at 10MHz (±100 ppb) At time of shipment. Factory calibrated at +21C.
Frequency Temperature Effects	< 10ppb
Frequency Aging Rate	< 100ppb/yr
10MHz External Lock Range	± 20Hz (typical), ± 10Hz (specified). 10MHz is for frequency counters only.

POWER METER ACCURACY

PARAMETER	MIN	TYPICAL	MAX	COMMENTS
Input Power Meter Accuracy		±3 dB	±4 dB	10 MHz to 50 GHz with Internal LOs

ISO17025 CALIBRATION

DESCRIPTION	SPECIFICATION
Frequency Offset Range HA7062C HA7062D	1 Hz – 40 MHz 1 Hz – 100 MHz

AC POWER & DATA I/O

DESCRIPTION	SPECIFICATION
AC Power Input Connector Type AC Input Rating	International AC Power Supply IEC 320-C13 100-240V _{AC} , 47-63Hz. Specify country at time of order for proper power cord.
Data I/O Interface	Ethernet, USB, and GPIB available to control the HA7063A as a standalone downconverter or a dual CW source.

SPECIFICATIONS – MEASUREMENT SPEED / CROSS CORRELATION

NOTE: Measurement times shown below are total data acquisition time. Data acquisition time does not include data transfer time to PC. Utilizing an Ethernet/LAN connection is recommended to best take advantage of the data acquisition speed of the instrument.

TABLE 1: DATA ACQUISITION SPEED

1 Cross-Correlation									
64 Samples		128 Samples		256 Samples		512 Samples		1024 Samples	
-	-	-	-	0.1Hz	17s	0.1Hz	34s	0.1Hz	1m8s
1Hz	1.1s	1Hz	2.2s	1Hz	4.3s	1Hz	8.6s	1Hz	17s
10Hz	0.3s	10Hz	0.5s	10Hz	1.1s	10Hz	2.2s	10Hz	4.3s
100Hz	0.1s	100Hz	0.1s	100Hz	0.3s	100Hz	0.5s	100Hz	1.1s
1kHz	<0.1s	1kHz	<0.1s	1kHz	0.1s	1kHz	0.1s	1kHz	0.3s
10kHz	<0.1s	10kHz	<0.1s	10kHz	<0.1s	10kHz	<0.1s	10kHz	<0.1s
100kHz	<0.1s	100kHz	<0.1s	100kHz	<0.1s	100kHz	<0.1s	100kHz	<0.1s
1MHz	<0.1s	1MHz	<0.1s	1MHz	<0.1s	1MHz	<0.1s	1MHz	<0.1s

10 Cross-Correlations									
64 Samples		128 Samples		256 Samples		512 Samples		1024 Samples	
-	-	-	-	0.1Hz	2m51s	0.1Hz	5m42s	0.1Hz	11m24s
1Hz	11s	1Hz	21s	1Hz	43s	1Hz	1m25s	1Hz	2m51s
10Hz	2.7s	10Hz	5.4s	10Hz	11s	10Hz	22s	10Hz	43s
100Hz	0.7s	100Hz	1.3s	100Hz	2.7s	100Hz	5.4s	100Hz	11s
1kHz	0.2s	1kHz	0.3s	1kHz	0.7s	1kHz	1.3s	1kHz	2.7s
10kHz	<0.1s	10kHz	<0.1s	10kHz	0.1s	10kHz	0.2s	10kHz	0.3s
100kHz	<0.1s	100kHz	<0.1s	100kHz	<0.1s	100kHz	<0.1s	100kHz	<0.1s
1MHz	<0.1s	1MHz	<0.1s	1MHz	<0.1s	1MHz	<0.1s	1MHz	<0.1s

TABLE 2: CROSS-CORRELATIONS vs. PHASE NOISE IMPROVEMENT

Improvement factor: $\text{dB} = 5\log N$ (N = No. of correlations)

Number of Correlations	1	10	100	1,000	10,000
dB Improvement	0dB	5dB	10dB	15dB	20dB

MEASURED NOISE FLOORS – MEASUREMENT SETUP

Holzworth and some alternate brand phase noise analyzers offer a cross correlation *confidence factor*, which is a noise floor approximation based on the DUT data being acquired. This confidence factor is often confused with being the noise floor of the instrument, but it is not the actual noise floor. Holzworth offers the unique feature to measure the true noise floor of the phase noise analysis products.

The HA7062C and HA7062D test systems were designed to provide direct access to the phase detectors (mixers) to enable measurements of the actual noise floor of the analyzer at any given frequency. The HA7063A offers this feature as a factory configured option.

To perform a noise floor measurement, the internal power splitter is bypassed to directly access the phase detectors of each channel while measuring two non-coherent frequency sources.

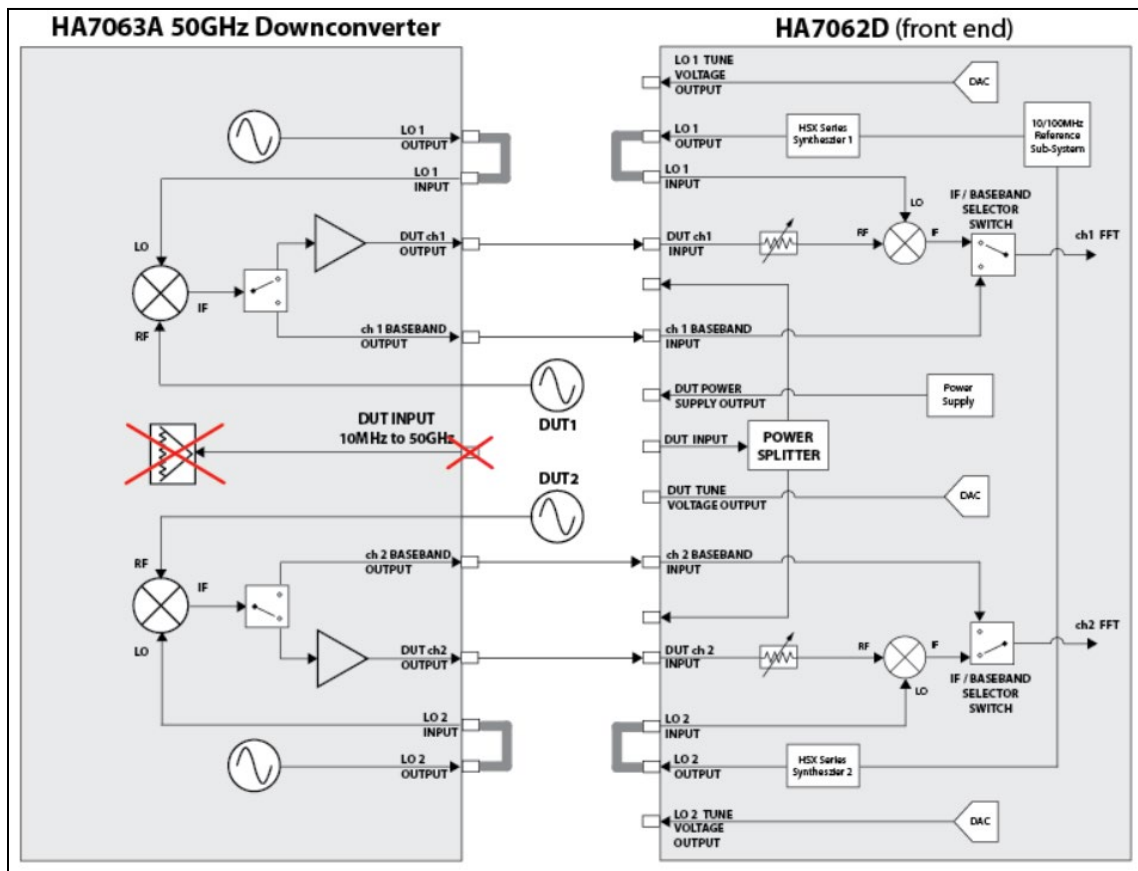

Figure 1: Noise Floor Measurement Block Diagram

For HA7063A units that do not include the option for phase detector access, Holzworth performs these measurements at predetermined frequency points, prior to product shipment.

MEASURED NOISE FLOORS - DATA

The data contained in this section demonstrates the noise floor capability of the HA7063A when used in conjunction with an HA7062C/D at 12GHz, 24GHz, and 50GHz. The plots reflect the actual noise floor for 10 correlations. For DUT frequencies of below 6GHz, the noise floors mirror those of the HA7062C/D (refer to each product specification). Further improvement in the noise floor can be achieved by utilizing more correlations (refer to Table 2, located on page 7).

The data contained in this section was acquired using a minimum offset frequency of 1Hz and data resolution of 256 points per decade. For reference, the data acquisition times for different number of correlations over a measurement bandwidth of 1Hz to 100MHz are approximated as follows:

1 correlation: 4.3s
10 correlations: 43s
100 correlations: 7 min, 9s

NOTE: Setting the instrument to a greater minimum offset frequency and/or a lower data resolution setting will further improve the measurement speeds.

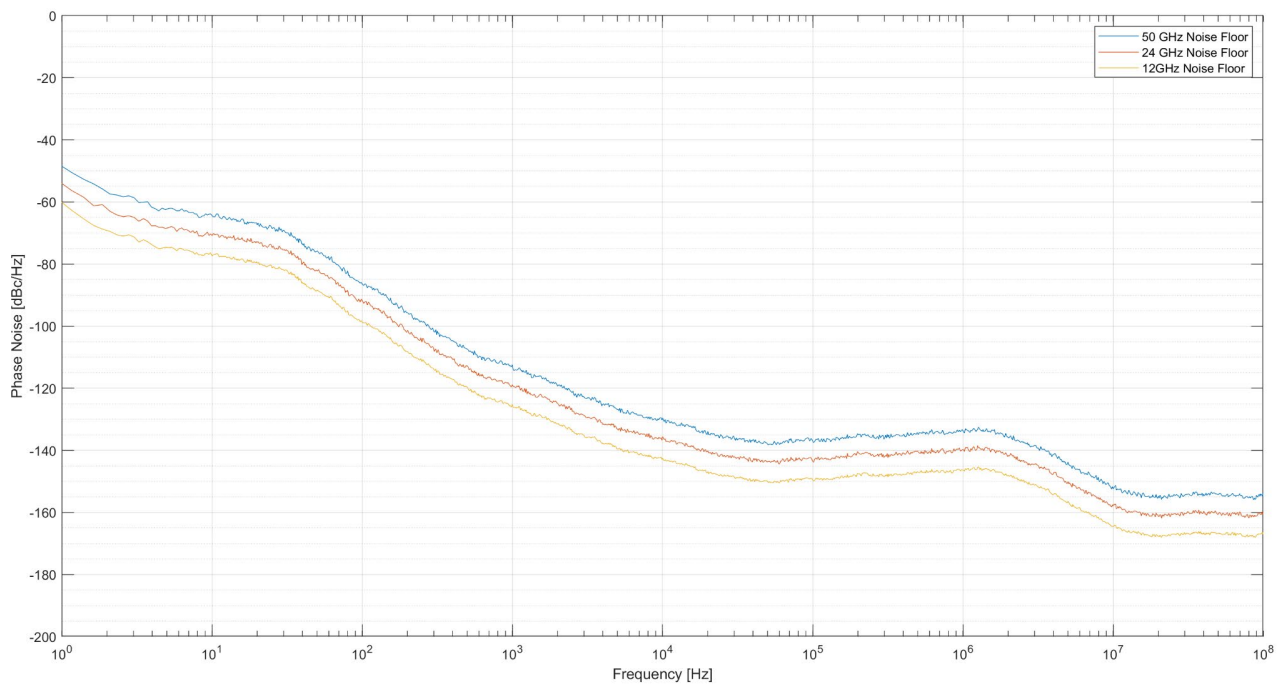

EXTERNAL LO MODE (cont.)

EXTERNAL LO's for DOWNCONVERSION – HA7063A LO INPUTS

Users may connect their own low noise LOs to the HA7063A LO Inputs in order to down-convert the incoming DUT signal. The HA7063A LO Input specifications are shown in the previous section and re-iterated below.

DESCRIPTION	SPECIFICATION
LO Input Connector	2.4mm (female), 50 ohm
LO Input Frequency Range	1 GHz to 50 GHz
LO Input Level	+15 dBm to +19 dBm
IF Frequency Range	DC to 400 MHz

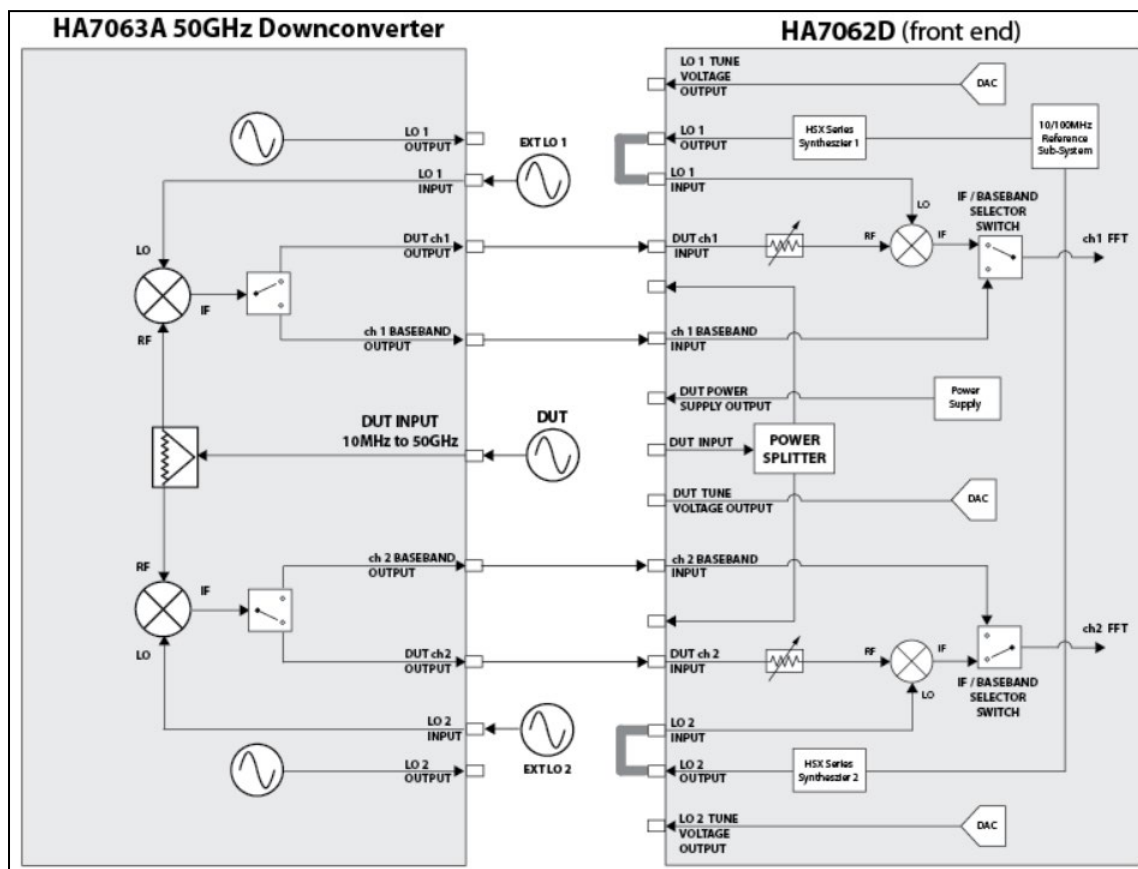

ADDITIVE MODE

STANDARD OPERATION - 1 GHz to 50 GHz

For standard operation in additive mode refer to the specifications and block diagram below. Refer to holzworth.com for the HA7062D/HA7062C datasheets for additive measurement specifications and measurement setups < 1 GHz. Holzworth offers the HX5100 Electronic Phase Shifter products for automating additive / residual measurements.

DESCRIPTION	SPECIFICATION
Input Frequency Range	1 GHz to 50 GHz
LO Input Level	+10 dBm to +19 dBm

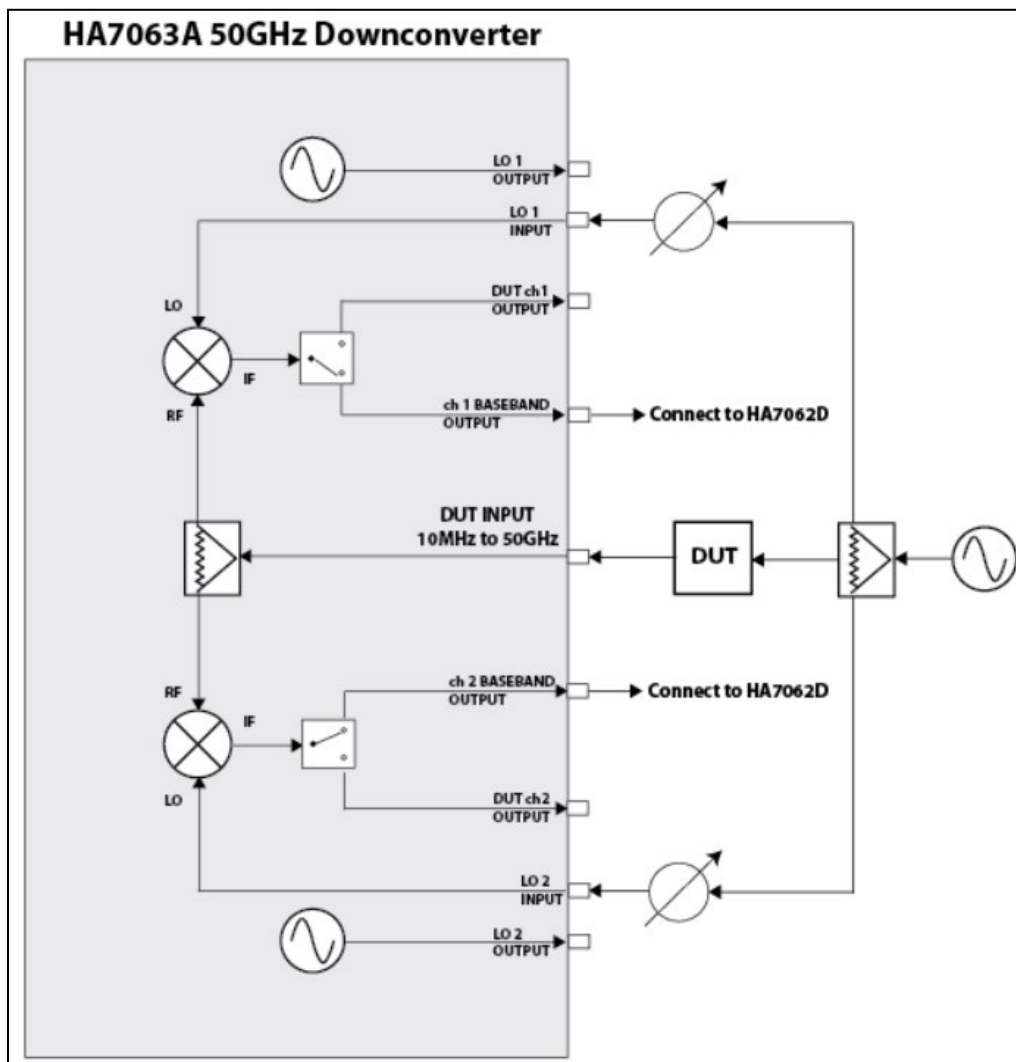

CONFIGURATION

MECHANICAL DIMENSIONS

All Holzworth Analyzer/Downconverter products come in a 1U high, rack mountable chassis form factor. Holzworth offers brackets for bench top operation and rack mount applications. The drawing below illustrates the size of a single chassis. The HA7062D front panel is currently shown below.

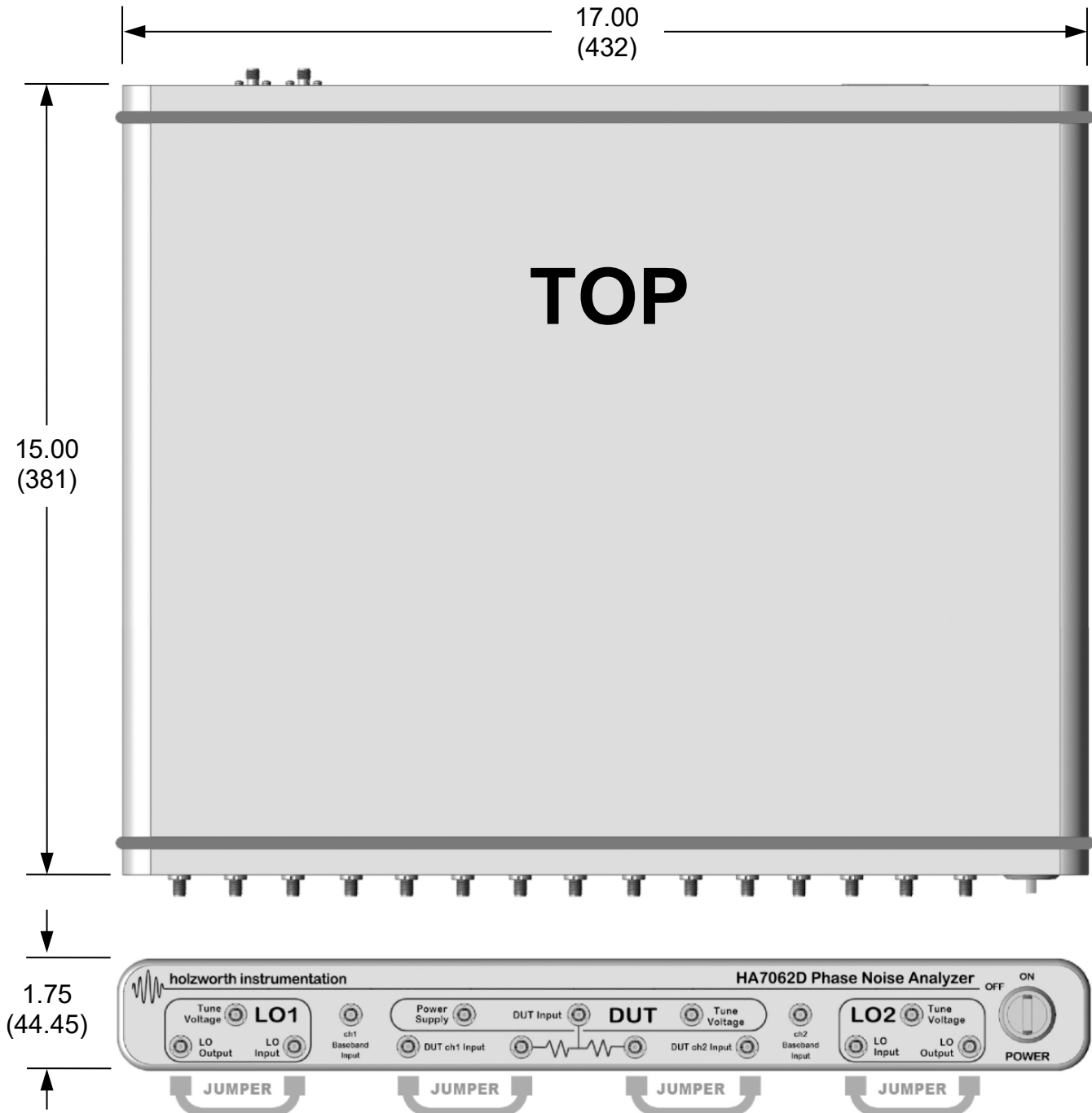



CONFIGURATION (cont.)

PHYSICAL

Dimensions (L x W x H) each chassis	1U high, 19" rack mount: 15in x 17in x 1.75in (381mm x 431.8mm x 44.5mm)
Weight (per chassis)	25 lb (11.34 kilograms) MAXIMUM

ENVIRONMENTAL

DESCRIPTION	SPECIFICATION (by design)
Operating Environment Temperature Humidity Altitude Vibration	+10C to +40C RH 20% to 80% at wet bulb temp. <29C (non-condensing) 0 to 2,000m (0 to 6,561 feet) 0.21 G-rms maximum, 5Hz to 500Hz
Storage (Non-Operating) Temperature Humidity Altitude Vibration	-10C to +60C RH 20% to 80% at wet bulb temp. <40C (non-condensing) 0 to 4,572m (0 to 15,000 feet) 0.5 G-rms maximum, 5Hz to 500Hz

CONFIGURATION (cont.)

OPTIONS & ACCESSORIES

Holzworth offers options and accessories to optimize the analyzer for an intended application. Specify all required options and/or accessories when requesting a quotation or placing a purchase order.

PART No.	DESCRIPTION	CLASSIFICATION
HX5100-x	Electronic Phase Shifter PAIR, Additive Measurements, 1 Octave Bandwidth, Specify fc	ACCESSORY
CASE-1U	Ruggedized Carrying Case with TSA security lock	ACCESSORY

INCLUDED HARDWARE AND CERTIFICATIONS

Each standard product delivery includes specific, standard hardware and certifications.

TYPE	DESCRIPTION	COMMENTS
HARDWARE	HA7062D PHASE NOISE ANALYZER	DELIVERABLE
HARDWARE	HA7063A 50 GHz Downconverter	DELIVERABLE
HARDWARE	AC Power Cord (7ft/2.1m). Specify country of end use.	DELIVERABLE
HARDWARE	Ethernet Cable (10ft/3m)	DELIVERABLE
HARDWARE	USB Cable (6ft/1.8m)	DELIVERABLE
HARDWARE	Null Modem RS-232 Cable (1ft/0.3m)	DELIVERABLE
WARRANTY	3 YEAR MANUFACTURER'S WARRANTY	NON-APPLICABLE
CERTIFICATE	CE COMPLIANCE CERTIFICATE <i>DIRECTIVE: 2004/108/EC, TEST STANDARD: EN 61326-1: 2006</i>	WEB DOWNLOAD
CERTIFICATE	RoHS COMPLIANCE CERTIFICATE <i>DIRECTIVE: 2002/95/EC</i>	WEB DOWNLOAD
CERTIFICATE	WEEE COMPLIANCE STATEMENT <i>DIRECTIVE: 2002/96/EC</i>	WEB DOWNLOAD

GENERAL OPERATION

While using the HA7063A, all data processing is performed internally on the coupled HA7062C/D. Measurement settings can be changed using serial commands sent to the HA7062C/D via any of the included communication options. Measurement results can be read back directly from the instrument, eliminating the use of the application GUI. This capability provides unparalleled operational flexibility, ideal for ATE applications.

Purchase of Holzworth phase noise analysis products includes full access to the C++ based GUI for hardware operation and viewing/saving data. All software/firmware upgrades and functionality additions are freely available for the life of the instrument at no additional cost to the user.

SOFTWARE

The Holzworth software team has designed an industry leading interface to provide an extremely user-friendly means to utilize the full functionality of the HA7063A + HA7062C/D on any Windows-based PC. In addition, any software/firmware updates are made available at no charge. Refer to the software menu summaries on page 16 for an overview of the GUI.

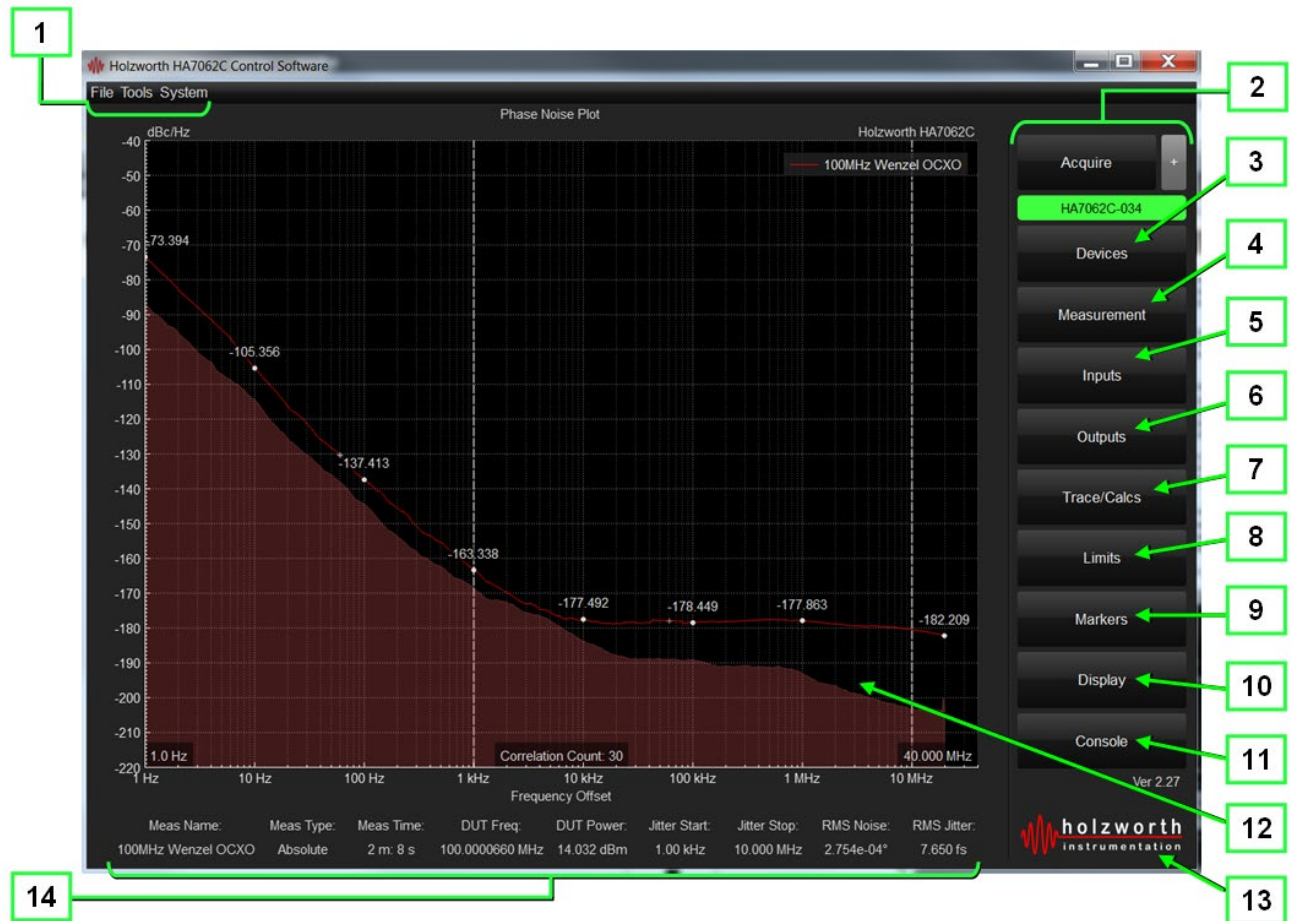

SOFTWARE (cont.)

1. **File:** Save, load, export, import data; and generate reports. The report generator captures the current plot and any measurement statistics (see page 18).
Tools: Quick access to the Tune Voltage outputs on the analyzer and displays input frequency and power for either LO1, LO2, or the DUT port. DC Monitor available for monitoring phase detector output.
System: Create instrument setting presets (saving time for commonly used measurement setups), view/save measurement debug files, and manually perform firmware updates.
2. **Acquire / +:** The 'Acquire' button initiates/stops a phase noise measurement. When the '+' button is depressed, selecting 'Acquire' will overlay new data trace's to any existing data captured in the plot area.
3. **Devices:** 'Devices' allows the user to view any HA7062C/D analyzer connected to the PC via Ethernet or USB. Instruments are listed by serial number and IP address or COM port. Connect to an instrument by clicking on it.
4. **Measurement:** Make changes to measurement type, offset range, jitter parameters, number of correlations, *etc.*
5. **Inputs:** Measure DUT/LO input power and frequency, calibrate and make adjustments for both internal and external LO sources.
6. **Outputs:** Provides voltage control for the DUT Power Supply, DUT Tune Voltage, External LO Tune range and Internal LO frequency/power levels.
7. **Trace/Calcs:** Access to data trace smoothing and spur removal functions.
8. **Limits:** Apply test limit lines to the plot area to create pass/fail conditions.
9. **Markers:** Adjust the number of data markers, their locations and marker interpolation.
10. **Display:** Provides access to plot data plot area modifications. Used to edit the x/y axis ranges, plot title, axis titles, trace names, plot export options, *etc.*
11. **Console:** The Console displays a log of instrument/measurement activity while also allowing the user to send commands directly to the instrument.
12. **Data Plot Area:** Displays acquired data: PM, AM, baseband, spurious, *etc.*
13. **Status Indicator:** The Holzworth shockwave logo doubles as a status bar/indicator while measurements are in progress. A measurement countdown timer is also displayed above the shockwave.
14. **Measurement Statistics:** Displays statistics of an active measurement or the currently selected data trace in the plot area.

SOFTWARE REPORT GENERATION

The automated report generation tool is a convenient feature for quickly generating a preformatted report that captures all traces and applicable data that is currently being displayed by the GUI. Each data trace actively contained in the plot area will be included in the report and color coordinated with its corresponding data.

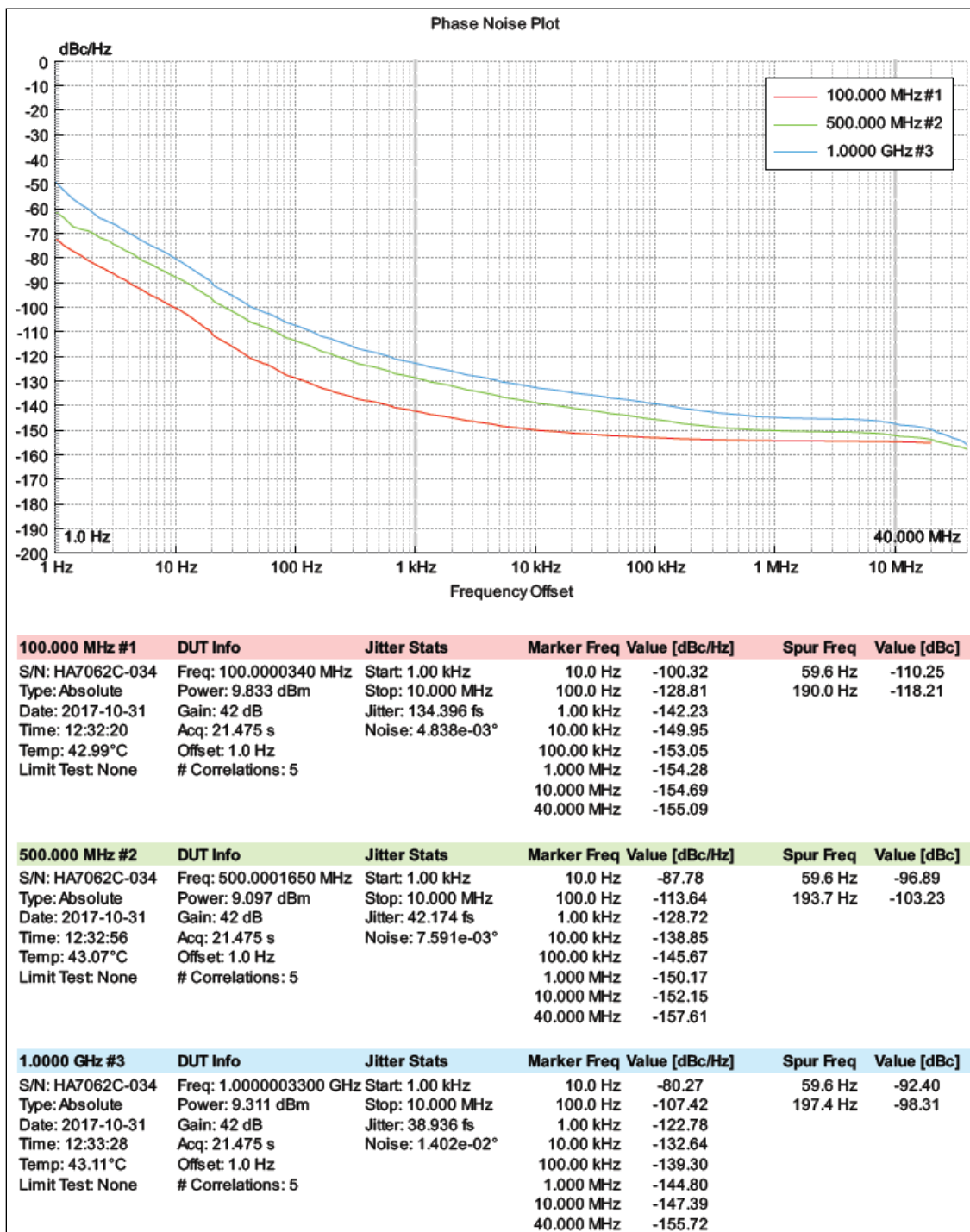



Holzworth

HA7063A

50GHz Downconverter

3 YEAR WARRANTY

All Holzworth phase noise analyzer products come with a standard 3 year 100% product warranty covering manufacturing defects and workmanship. All product repairs and maintenance must be performed by Holzworth Instrumentation. Holzworth reserves the right to invalidate the warranty for any product that has been tampered with or used improperly. Refer to Holzworth Terms & Conditions of Sales for more details.

Holzworth products are proudly designed and assembled in the USA.



CONTACT INFORMATION

Contact Holzworth directly for a product quotation, a product demonstration, or for technical inquiries.

Holzworth Instrumentation Sales Support

Phone: +1.303.325.3473 (option 1)

Email: sales@holzworth.com

Holzworth Instrumentation Technical Support

Phone: +1.303.325.3473 (option 2)

Email: support@holzworth.com

www.HOLZWORTH.com

